

DCR and CDR LENS SYSTEM WITH XM2 ATTACHMENT KIT INSTALLATION GUIDE

XM2 Plate horizontally centered on projector lens and attached to projector **or** clamped between larger projector and ceiling mount **or** mounted to a shelf under the projector. Allow 3.5" (90mm) of the plate in front of the projector lens.

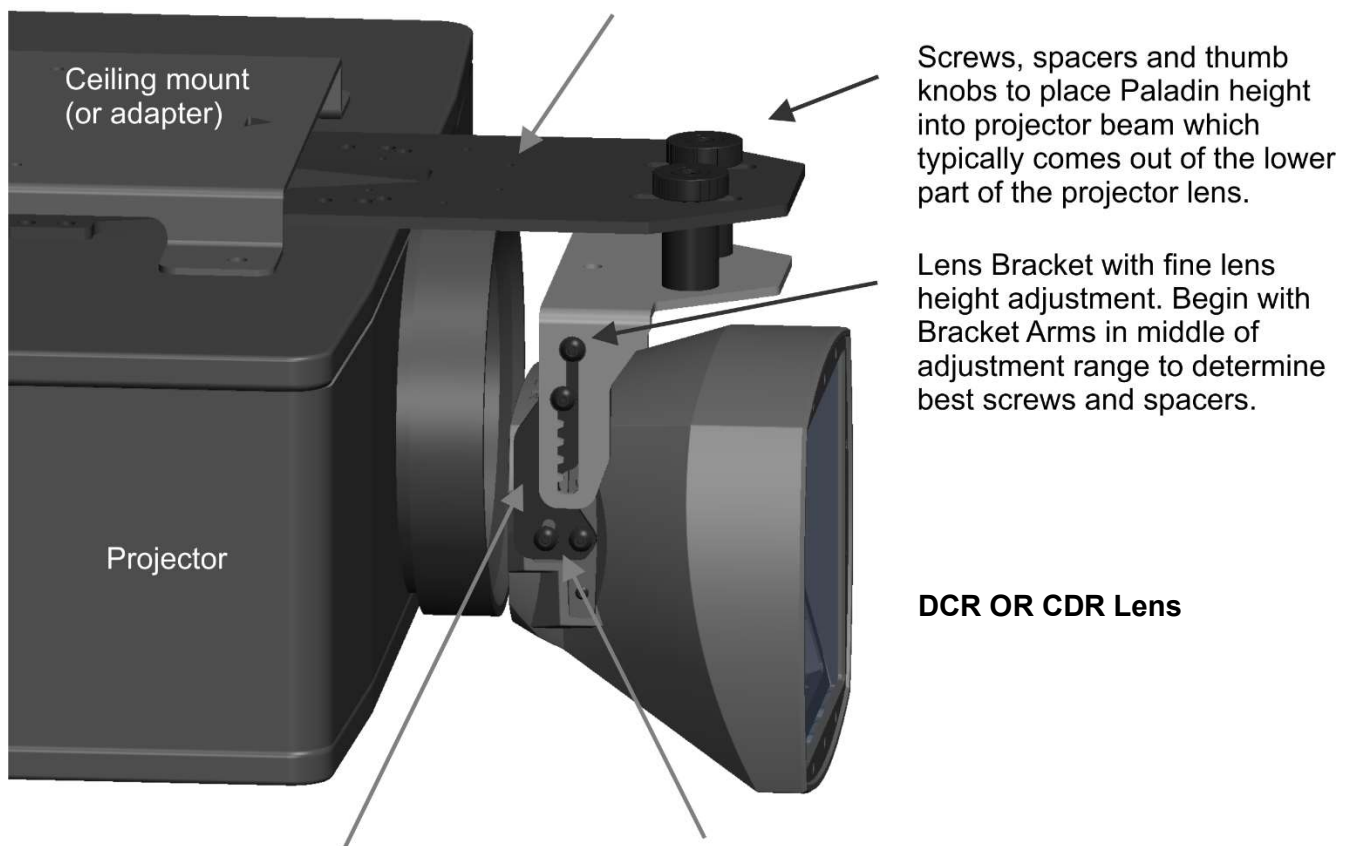

Screws, spacers and thumb knobs to place Paladin height into projector beam which typically comes out of the lower part of the projector lens.

Lens Bracket with fine lens height adjustment. Begin with Bracket Arms in middle of adjustment range to determine best screws and spacers.

DCR OR CDR Lens

Bracket Arms. May be inverted with Lens Bracket for shelf mount with XM2 Plate under shelf-mounted projector. (lens remains in orientation shown)

Pivot/tilt for image height adjustment in combination with projector vertical lens shift. NOTE: This is a key adjustment for best image geometry so experience is encouraged.

STEP 1 - INSTALL THE XM2 ATTACHMENT PLATE

The XM2 attachment kit includes the XM2 steel plate to position Panamorph lenses in front of the projector lens. Since the plate is completely flat it can be inserted between the projector and its ceiling mount or attached to a shelf under the projector or attached directly to certain projector models (see Direct Attachment section).

CONTENTS (in "Kit Parts" box)

(1) XM2 Plate with these instructions	
(1) Lens Bracket (only with complete lens systems)	
(1) Driver Kit with 5/32" hex bit	
(2) Screw, Bracket Attachment	1/4"-20 x 3/4", black
(2) Screw, Bracket Attachment (long)	1/4"-20 x 1 5/8", black
(2) Screw, Bracket Attachment (X long)	1/4"-20 x 2 3/4", black
(2) Screw, Bracket Attachment (XX long)	1/4"-20 x 4", black
(2) Spacer, 1" Bracket Attachment	3/4"D x 1" long, black
(2) Spacer, 2" Bracket Attachment	3/4"D x 2" long, black
(4) Screw, Lens Bracket	#8-32 x 1/4", black
(2) Thumb Knob, Bracket Attachment	
(2) Screw, Stabilizer	#6-32, 1" black plastic
(2) Screw, Epson/JVC Plate Attachment	M4x18mm, silver
(2) Screw, Epson/JVC4K Plate Attachment	M4x25mm, silver
(3) Screw, Sony Plate Attachment	M5x14mm, silver
(2) Spacer, Epson LS	1/2" OD, 3/16" long, black
(2) Spacer, Epson 6040	1/2" OD, 1/2" long, black

DIRECT ATTACHMENT OF THE XM2 PLATE

A. Lay the XM2 Plate over the inverted projector to identify the mounting holes

- E1 - **Epson** LS
- E2 - **Epson** 6040
- J - **JVC** (RS4500 forward)
- S1 - **Sony** 4K ES other than VW5000ES.

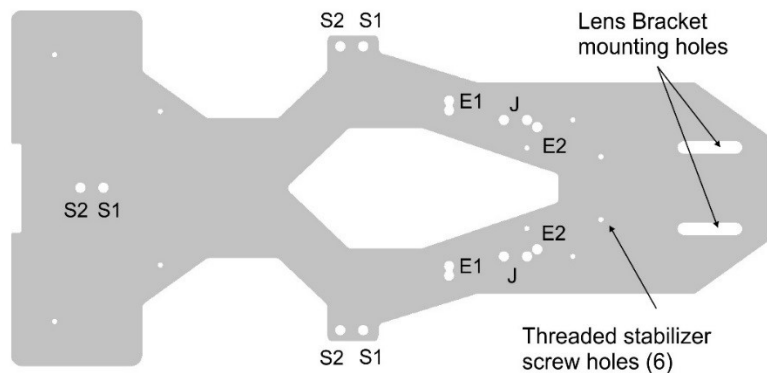

- B. EPSON PROJECTORS ONLY. Set the XM2 Plate aside. For Epson 10XXXLS projectors place a 3/16" spacer over each Panamorph mounting hole. For the Epson 6040UB projector, place a 1/2" spacer over each Panamorph mounting hole. Replace the XM2 Plate over the inverted projector without disturbing the spacers.
- C. SONY PROJECTORS ONLY (other than VW5000ES). Place the ceiling mount adapter over the XM2 Plate and align with the projector mounting holes. If no ceiling mount is used then add washers (not included) to replace the thickness of the ceiling mount adapter for proper screw length.
- D. Insert and tighten the appropriate Plate Attachment Screws through the XM2 Plate and into the projector. **CAUTION: IF THE PLATE ATTACHMENT SCREWS DO NOT FULLY THREAD INTO THE PROJECTOR DO NOT FORCE THEM.** In this case you may need to either use shorter screws or add washers.
- E. If extra rigidity is desired, insert the two plastic stabilizer screws through the XM2 Plate in the holes shown as forward as possible but so that they still make good contact with the projector. Only tighten until they make contact (and no farther).

ATTACHMENT TO PROJECTORS WITHOUT XM2 ATTACHMENT HOLES OR TO A SHELF UNDERNEATH

If there are no projector holes for direct XM2 plate attachment, such as with the Sony VPL-VW5000ES and most Digital Projection models, the cleanest installation is to allow a roughly 3/16" (5mm) gap between the projector and ceiling mount; insert the XM2 plate into that gap while centered on the projector lens, and leave 3.5" (90mm) of plate extending in front of the projector lens. **Use appropriate length attachment screws from the ceiling mount through to the projector for maximum security.** Alternatively, secure the XM2 plate to a shelf underneath the projector leaving the same extension in front of the projector lens.

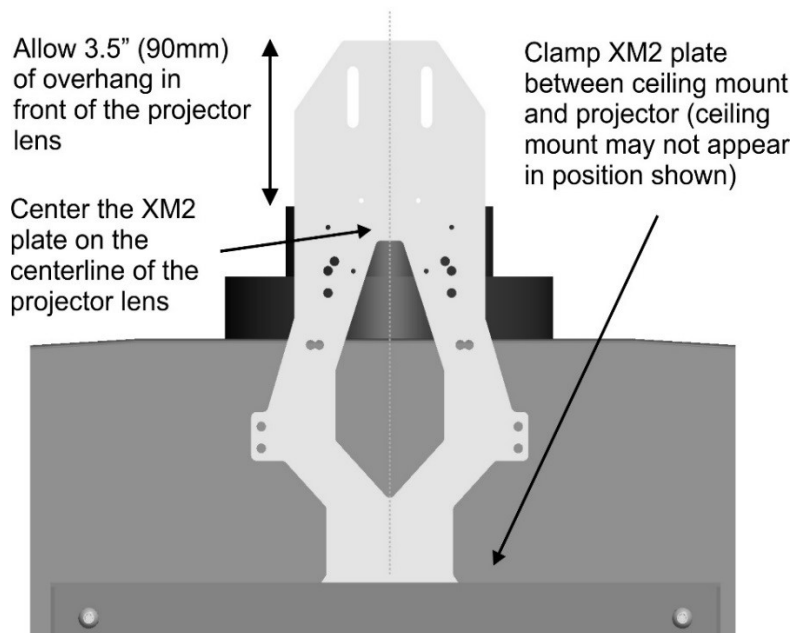

STEP 2 – PREPARATION BEFORE LENS INSTALLATION

- A. Fine tune your projection system setup now.** The projector should be centered within a few inches of the horizontal screen center, pointed at the screen center (ie using minimal horizontal lens shift) with roll, tilt and yaw adjusted so that test pattern lines are square with the screen edges.
- B. Use a 2.4:1 movie for lens installation and set the projector (or external processor if used) to the vertical stretch mode.** Projector test patterns do not typically represent actual movie aspect ratios so set your theater up with a real movie. Most UltraWide movies since 1971 are in the 2.4:1 (or 2.39:1) aspect ratio but check the back of a Blu-ray movie container to confirm. Set Sony projectors to V-Stretch and 1.24x for DCR (1.32x for CDR). Set JVC projectors to Anamorphic C (Anamorphic A for CDR). Use TheaterScope for Digital Projection projectors (CDR).
- C.** Adjust the projector zoom so that the 2.4:1 movie fully fills the width of your screen. For a 2.4:1 screen adjust the projector's vertical lens shift to provide about 80% of the overscan above the screen and about 20% below. For a 2.35:1 screen adjust the vertical lens shift for roughly even overscan above and below.

STEP 3 - INSTALL THE LENS

- A.** Find the Lens Bracket which is shipped in the Kit Parts box separate from the Lens. Please leave the protective film on the lens for now. **For a shelf mounted projector see “GENERAL TIPS” for inverting the Lens Bracket and Bracket Arms.**
- B.** From the Kit Parts, select the two best lengths of Bracket Attachment Screws and matching Spacers that will vertically position the projector beam through the Lens when the Bracket Arms are in their mid-height adjustment positions (see front page illustration). You may wish to preview step 3E below. Note that projectors typically project the beam out of the lower area of the projection lens down toward the screen so the Panamorph lens will also be aligned lower than the projection lens to properly pass the beam. Thread the chosen Bracket Attachment Screws up through the Lens Bracket threaded holes and tighten using the 5/32” hex bit included with the driver.
- C.** Attach the Lens to the Lens Bracket by inserting the four #8-32 Bracket Screws (two on each side) through the toothed Lens Bracket height-adjustment slots and into the Bracket Arms.
- D.** Attach the Lens Bracket (with Lens attached) to the Attachment Plate by directing the Bracket Attachment Screws (now in the Lens Bracket) up through the slotted holes (XM2) and secure using the two Thumb Knobs (see front page illustration).

- E. Remove the lens protective film. The projector should be showing a 2.4:1 movie at this point. Make sure the projector beam is passing completely through the Lens by setting the Bracket Arms into the appropriate toothed locations in the Lens Bracket slots and then secure the height adjustment screws. Fine tune the projector lens zoom to overscan any residual geometric distortion onto the screen border.
- F. Adjust the vertical dimension of the 2.4:1 movie by loosening the Pivot/Tilt screws and tilting the Lens. This will not only move the image up or down but will also slightly change the image height. Then adjust the projector vertical lens shift to bring the image back onto the screen. This process may take several iterations to best fit the 2.4:1 movie to the screen. Finally, tighten the Pivot/Tilt screws to secure.
- G. Loosen the Thumb Knobs, move the Lens toward the projector to minimize the gap to the projector lens. Retighten the Thumb Knobs and fine tune projector focus.

GENERAL TIPS

Image geometry adjustments. If the image is higher or taller on one side than the other but it did not have this issue before lens installation then the Panamorph lens is either higher on one side than the other or is more forward/back on one side than the other. If both sides look similar (ie symmetric) then these adjustments are proper. Residual barrel-shaped image distortion should be expected with DCR and CDR lenses. This distortion decreases with increased distance from projector to screen.

If the top or bottom edge of the movie is more curved than the other or the movie vertical dimension does not fit the screen then repeat Step 3F.

Inverting the lens bracket for shelf mounting. When shipped, the Bracket Arms are attached to Panamorph lenses for suspending from the XM2 plate above the projector. These Arms can be removed from the lens and inverted so that the Lens is still properly oriented with the bracket facing down to mount to a shelf. Note that this typically restricts how much the lens can be tilted down so the Bracket Arms may need to be angled away from the Lens Bracket to provide this extra tilt if needed during step 3F. You may also need to mount the attachment system directly to the shelf instead of the projector with enough vertical spacing to allow the Panamorph lens to pass the entire projector beam (possibly even raising the projector) since much of the Panamorph lens will be below the center of the projector lens.

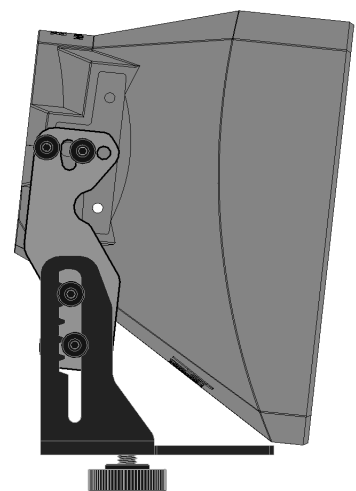

Projector modes for different content. Please see projector viewing modes pages at www.panamorph.com for your particular projector brand.

Convergence correction. At small throw ratios Paladin lenses can create color fringing which increases toward the top and bottom edges of the image. While typically only visible when close to the screen this color fringing can be corrected during lens setup by features available in Sony, Epson and JVC projectors, taking approximately 5 to 30 minutes to adjust depending on the projector model and level of desired correction.

Epson: Menu -> Extended -> Panel Alignment. See the user manual for more detailed discussion regarding “Adjusting the Color Convergence”.

JVC: Menu -> Installation -> Pixel Adjust. Please refer to the “Zone Adjust Operation Procedure” in the user manual.

Sony: Menu -> Installation -> Panel Alignment. Please refer to the section on “Panel Alignment -> Zone” in the user manual.

SPECIFICATIONS. **Lens:** weight 3.5 lbs (1.6 kg), 5.7” (145mm) height, 6.5” (165mm) width, 4” (102mm) depth (DCR) or 4.5” (114mm) depth (CDR). **Allow a minimum of 4.5” (114mm) (DCR) or 5.0” (128mm) (CDR) in front of the projector for installation clearance.** **XM2 plate** and attachment components add an additional 5 lbs (2.27 kg) to the system. XM2 plate is 3/16” (4.75mm) thick steel with general dimensions of 17.4” (442mm) length by 8” (505mm) width.

CLEANING. Small amounts of dust and wipe marks are very noticeable on lens surfaces with a high brightness projection beam but typically will not impact your image as much as damage from excessive cleaning in pursuit of a “perfect” optical surface. Occasionally blowing off the lens surfaces with clean air is the best way to keep long term performance. If there is any excessive residue or build-up then it is recommended that you clean the optics with professional lens cleaning supplies such as from a camera store **while the lens is in front of the lit beam of the projector.** This will allow you to quickly see your results and if the process is causing any damage.

LIMITED WARRANTY. Panamorph, Inc. warrants this product against any change in performance or functionality for a period of twenty-four months from our ship date. During this period, a unit may be repaired or replaced, at the discretion of Panamorph, Inc., by returning it in its original packaging with a copy of your receipt. This warranty does not cover damage resultant from lack of prudent care, accident or misuse (including use with other products in ways not intended); any cosmetic damage not reported within 15 days of purchase; or any performance change caused by the environment in which it is used. All damages are limited to the cost of the product. This warranty is not transferable.